

TRIM—PASSENGER SEAT RUBS AGAINST DOOR PANEL

Article No.
03-1-5

FORD: 1999-2003 MUSTANG

ISSUE

Some vehicles may exhibit the passenger seat rubbing against the door panel or trim. This may result in a squeak type noise, especially in vehicles equipped with leather seating. This may be caused by the seat position in the vehicle.

ACTION

To service, install shims (washers) to move the seat-back away from the door trim. Refer to the following Service Procedure for details.

SERVICE PROCEDURE

CAUTION

SEAT TRACK MAY BE SPRING LOADED. THIS MAY CAUSE THE SEAT TRACK TO MOVE DURING REMOVAL.

1. Remove the front passenger seat per Workshop Manual procedure listed in Section 501-10.
2. Remove the front passenger seat backrest and latch per Workshop Manual procedure listed in Section 501-10. Only remove the top two bolts of latch (Figure 1). Discard lower bolt.
3. Obtain Seat Shim Kit 1R3Z-63000A25-AB.
4. Install four (4) of the 1.5mm-thick washers (8 included in kit with a 12.1- 12.4mm I.D.) between the seat backrest bracket and the seat bottom cushion frame (Figure 2).
5. Install other four (4) of the 1.5mm-thick washers between the seat backrest latch and the seat backrest frame at the upper bolt location (Figure 1).
6. Install the three (3) 2mm thick washers (smaller I.D.) between the seat backrest latch and the seat backrest frame at the lower bolt location (Figure 1).
7. Using the bolt that is provided in the kit for the lower hole, Re-install the seat backrest latch using the reverse of the procedure listed in Section 501-10.
8. Re-install the seat backrest using the reverse of the procedure listed in Section 501-10.
9. Re-install seat into vehicle using the reverse of the procedure listed in Section 501-10. Slide seat towards center console before tightening seat to floor.
10. Verify that seat does not touch door panel.

PART NUMBER	PART NAME
1R3Z-63000A25-AB	Kit - Seat Shim

OTHER APPLICABLE ARTICLES: NONE

WARRANTY STATUS: Eligible Under The Provisions Of Bumper To Bumper Warranty Coverage

OPERATION	DESCRIPTION	TIME
030105A	Install Shims To Move Seat Away From Door Trim Panel (Includes Time To Remove And Install Seat)	0.8 Hr.

DEALER CODING

BASIC PART NO.	CONDITION CODE
7661018	07

OASIS CODES: 101000, 107000, 702000, 702300

NOTE: The information in Technical Service Bulletins is intended for use by trained, professional technicians with the knowledge, tools, and equipment to do the job properly and safely. It informs these technicians of conditions that may occur on some vehicles, or provides information that could assist in proper vehicle service. The procedures should not be performed by "do-it-yourselfers". Do not assume that a condition described affects your car or truck. Contact a Ford, Lincoln, or Mercury dealership to determine whether the Bulletin applies to your vehicle.

Article No. 03-1-5 Cont'd.

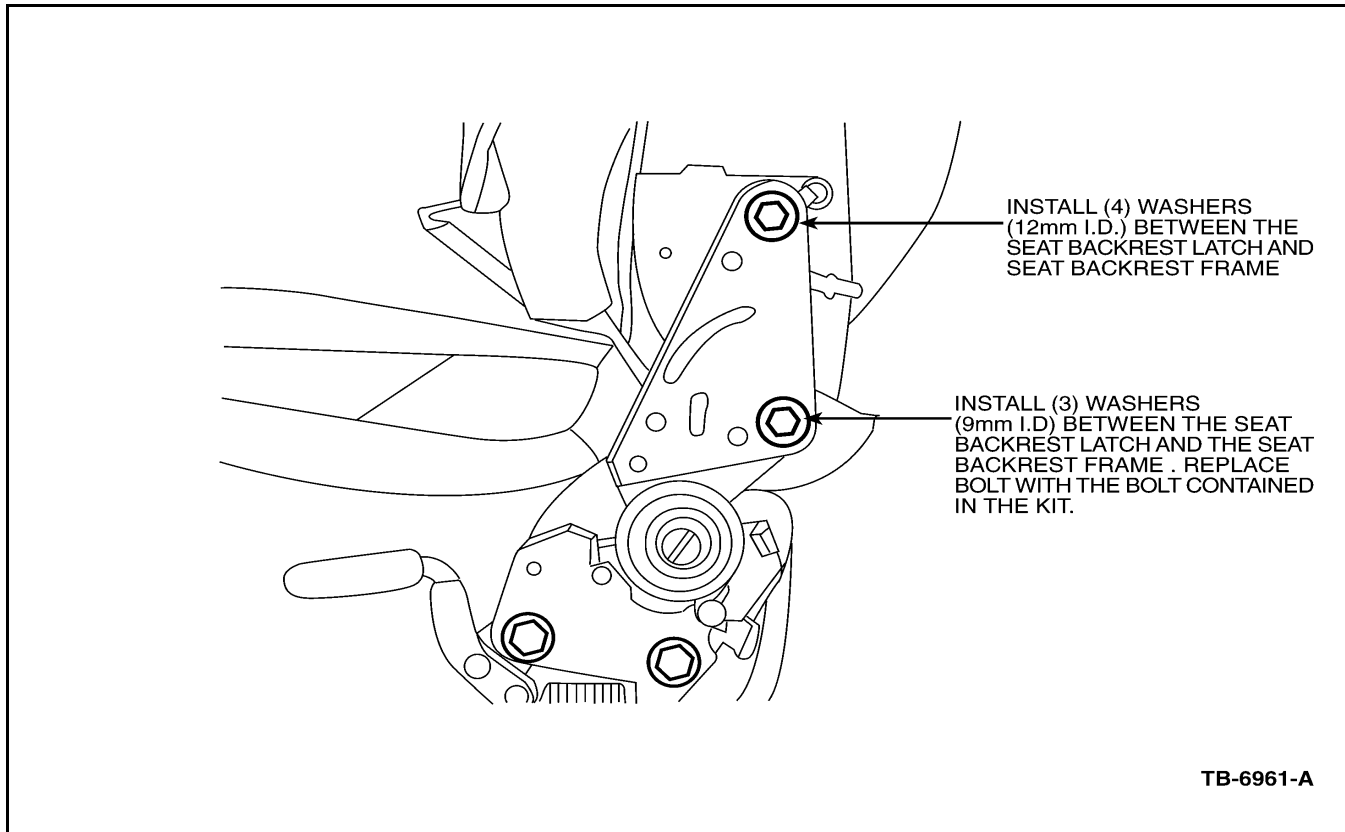

Figure 1 - Article 03-1-5

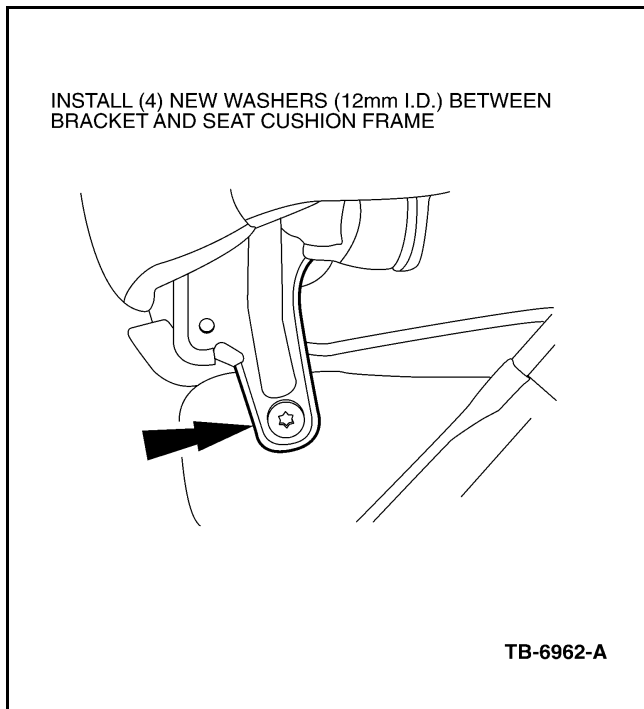

Figure 2 - Article 03-1-5